

Campus Network Design Workshop

Structured Cabling

This document is a result of work by the Network Startup Resource Center (NSRC at <http://www.nsrc.org>). This document may be freely copied, modified, and otherwise re-used on the condition that any re-use acknowledge the NSRC as the original source.



UNIVERSITY OF OREGON



Structured Cabling Systems

- Only two types of cabling:
 - Unshielded twisted pair copper – provides service to individual computers and between network racks
 - Fiber optic cabling – provides service to buildings and between network racks
- Everything is run in a star configuration

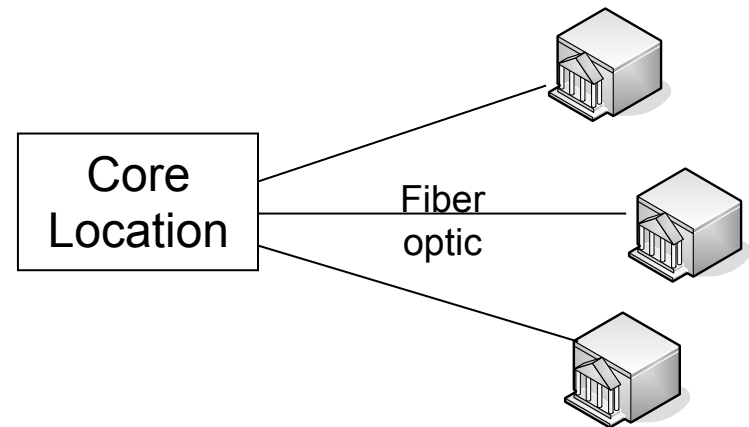
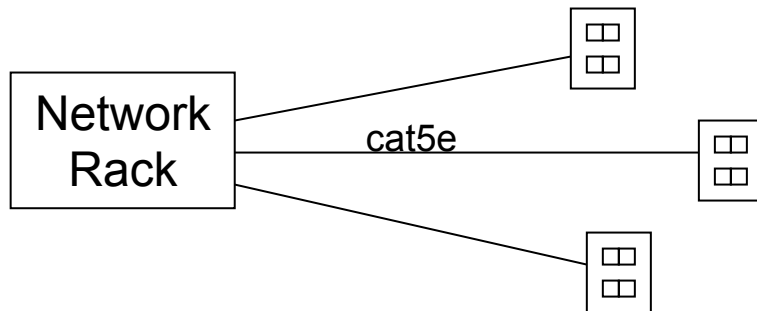

Unshielded Twisted Pair Cable

- Run in star configuration from network rack location to individual outlets in offices or labs.
- Run at least 2 cables to every outlet – I recommend 4 if you can afford it.
- Run 4 to 6 cables between network racks if the distance is less than 90 meters
- Question: what type of cable to run? Cat5, cat5e, Cat6, ???



What type of UTP

- What speed does each type support?

Cable Type	Max Speed	Max Distance	Cost Factor
Category 5	100Mbps	100m	1x
Category 5e	1000Mbps	100m	1x
Category 6	1000Mbps	100m	1.5x
Category 6	10,000Mbps	57m	1.5x
Category 6a	10,000Mbps	100m	3x

- Strongly recommend category 5e cabling.



Fiber Optic Cabling

- Two basic types of fiber
 - Multi Mode

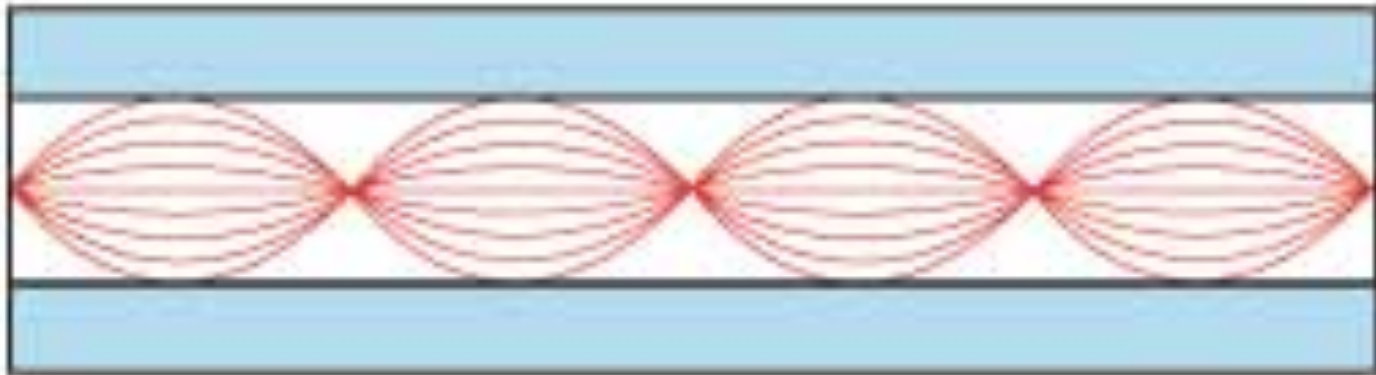

- Single Mode

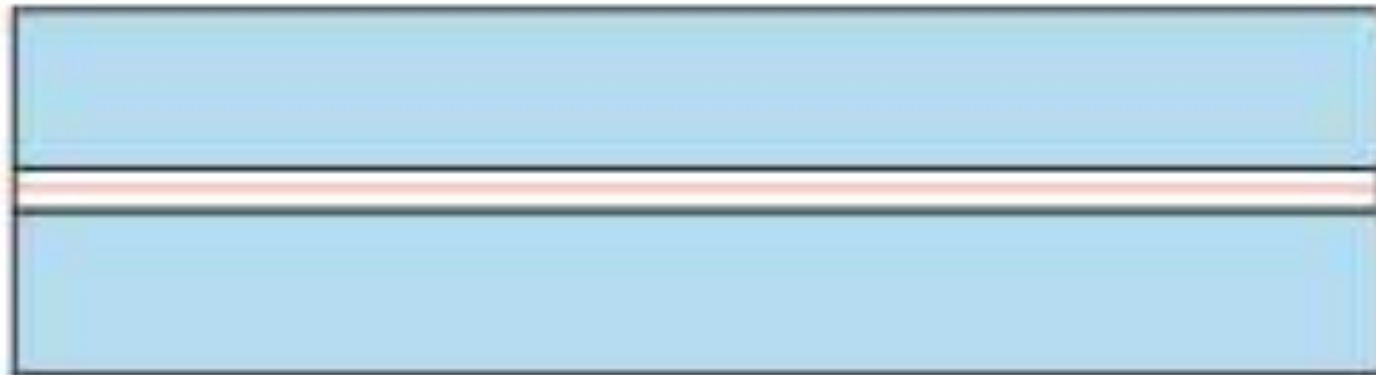

Multi Mode Fiber

- Two basic types:
 - 62.5 micron core. Legacy, older style
 - 50 micron core. Newer
- A number of standards to be aware
 - G.651 – 50 micron
 - OSI/IEC 11801 OM1 – 62.5
 - OSI/IEC 11801 OM2 – 50 micron
 - OSI/IEC 11801 OM3 – 50 micron laser optimized
 - OSI/IEC 11801 OM4 – 50 micron higher bw



Single Mode Fiber

- All have core between 8 and 10 micron
- Standard types:
 - OS1 and OS2 (OSI/IEC 11801 types)
 - ITU G.652 (A, B, C, D)
 - ITU G.653 – 1310/1550 with EDFA amps
 - ITU G.654 – 1550 only
 - ITU G.655 – 1550/1625 for long haul DWDM
 - ITU G.656 – 1460/1625 for long haul DWDM
- You want G.652.D or OS2 single mode



Types of Optical Interfaces

Standard	Speed	Fiber Type
100baseFX	100Mbps	MM
1000baseSX	1Gbs	MM
1000baseLX/LH	1Gbs	MM or SM
10GbaseSR	10Gbs	MM
10GbaseLRM	10Gbs	MM
10GbaseLR	10Gbs	SM
10GbaseER	10Gbs	SM



Optical Interfaces: Cost & Distance

Standard	Cost*	OM1	OM2	OM3	OM4	G.652.D
100baseFX	\$125	2km	2km	2km	2km	No
1000baseSX	\$100	275m	550m	1km	1.1km	No
1000baseLX/LH	\$169	500m	500m	500m	500m	10km
10GbaseSR	\$475	33m	82m	300m	550m	No
10GbaseLRM	\$785	220m	220m	300m	400m	No
10GbaseLR	\$495	No	No	No	No	10km
10GbaseER	\$6050	No	No	No	No	40km

*pricing for genuine Cisco products from networkhardwareoutlet.com.
In the USA, these products can be purchased cheaper than shown.



UNIVERSITY OF OREGON



Fiber Price Comparison

- Single mode fiber cabling is cheaper
- Multi mode optical interfaces are cheaper
- What makes sense for your campus?

Fiber Type	Cost per km*
OM1 (62.5 legacy)	\$4,270
OM2 (50 legacy)	\$2,854
OM3 (50 laser optimized)	\$7,248
OM4 (new std)	\$7,990
G.652.D (single mode)	\$938

*Pricing based on 12-fiber outdoor cable, Corning 012TU4-T41xxD20, quote obtained in April, 2013

Simple Fiber Pricing Example

- Consider the simple network below
 - Total fiber length 1400m
 - 8 optical interfaces

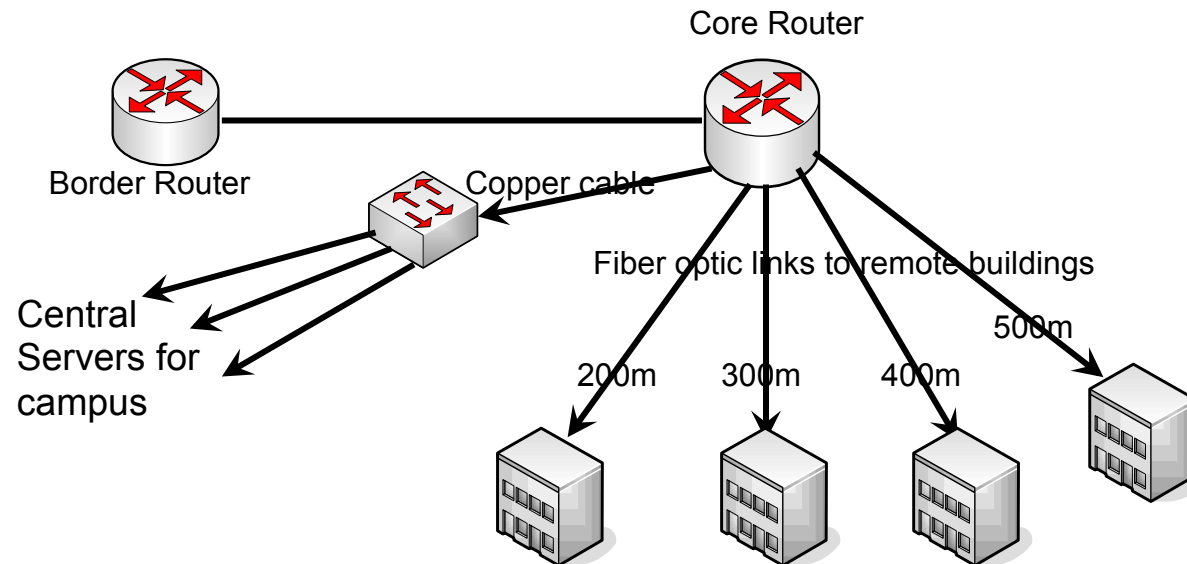

Pricing Example – 1Gig Links

- Use cheapest optical interface possible, but note that cheap interface is distance limited based on fiber type

Fiber Type	Fiber Cost	Optics	Total Cost
OM1	\$5,978	2x1000baseSX@100 6x1000baseLX@169 = \$1,214	\$7,192
OM2	\$3,996	8x1000baseSX@100 = \$800	\$4,796
OM3	\$10,147	8x1000baseSX@100 = \$800	\$10,947
OM4	\$11,186	8x1000baseSX@100 = \$800	\$11,986
G.652.D	\$1,313	8x1000baseLX@169 = \$1,352	\$2,665



Pricing Example – 10Gig Links

- Note that some fiber types won't support 10Gig over the required distances

Fiber Type	Fiber Cost	Optics	Total Cost
OM1	\$5,978	Can't do do 10G farther than 220m	No
OM2	\$3,996	Can't do do 10G farther than 220m	No
OM3	\$10,147	Can't do do 10G farther than 300m	No
OM4	\$11,186	8x10GbaseSR@475 = \$3,800	\$14,986
G.652.D	\$1,313	8x10GbaseLR@495 = \$3,960	\$5,273

Fiber Pricing Exercise

- See workshop wiki
- Work in pairs or threes
- Do network with all OM1 fiber, then all OM2 fiber, then all OM3 fiber
- Do for both 1G backbone network and 10G backbone network
- Which type of fiber would be best?



Fiber Optic Recommendations

- Don't install any Multi mode
- Only install Single mode
- Run in star configuration from core network location to individual buildings
- Run in star configuration inside of buildings from main network rack to other network racks
- To reduce costs, can run large fiber cable from core to some remote location, then smaller cables from there to surrounding buildings



Star Configuration

- Plan for future -- Install enough fiber
 - Between Buildings: 6 single mode from core to each building (consider 12 fibers if you can afford it)
 - Inside of buildings: 6 single mode between network racks
 - Can build incrementally

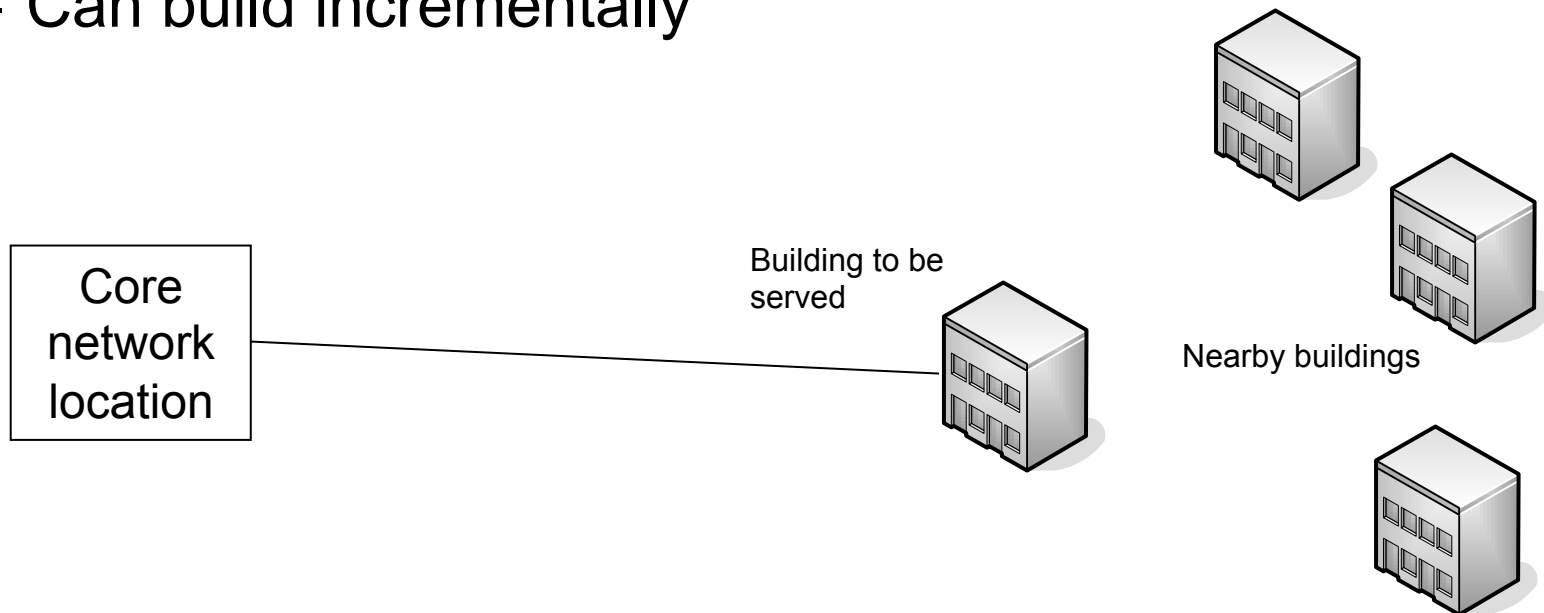

Star Configuration

- Plan for future -- Install enough fiber
 - Between Buildings: 6 single mode from core to each building (consider 12 fibers if you can afford it)
 - Inside of buildings: 6 single mode between network racks
 - Can build incrementally

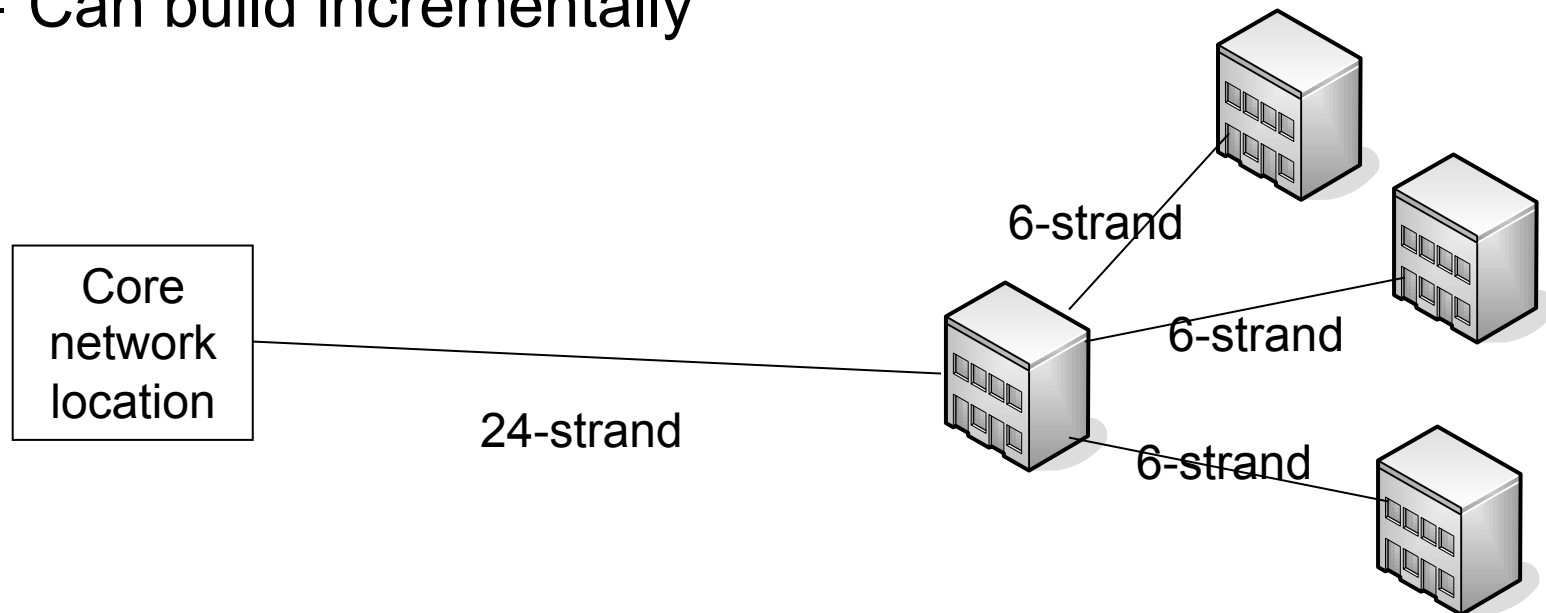

Fiber Optic Topology

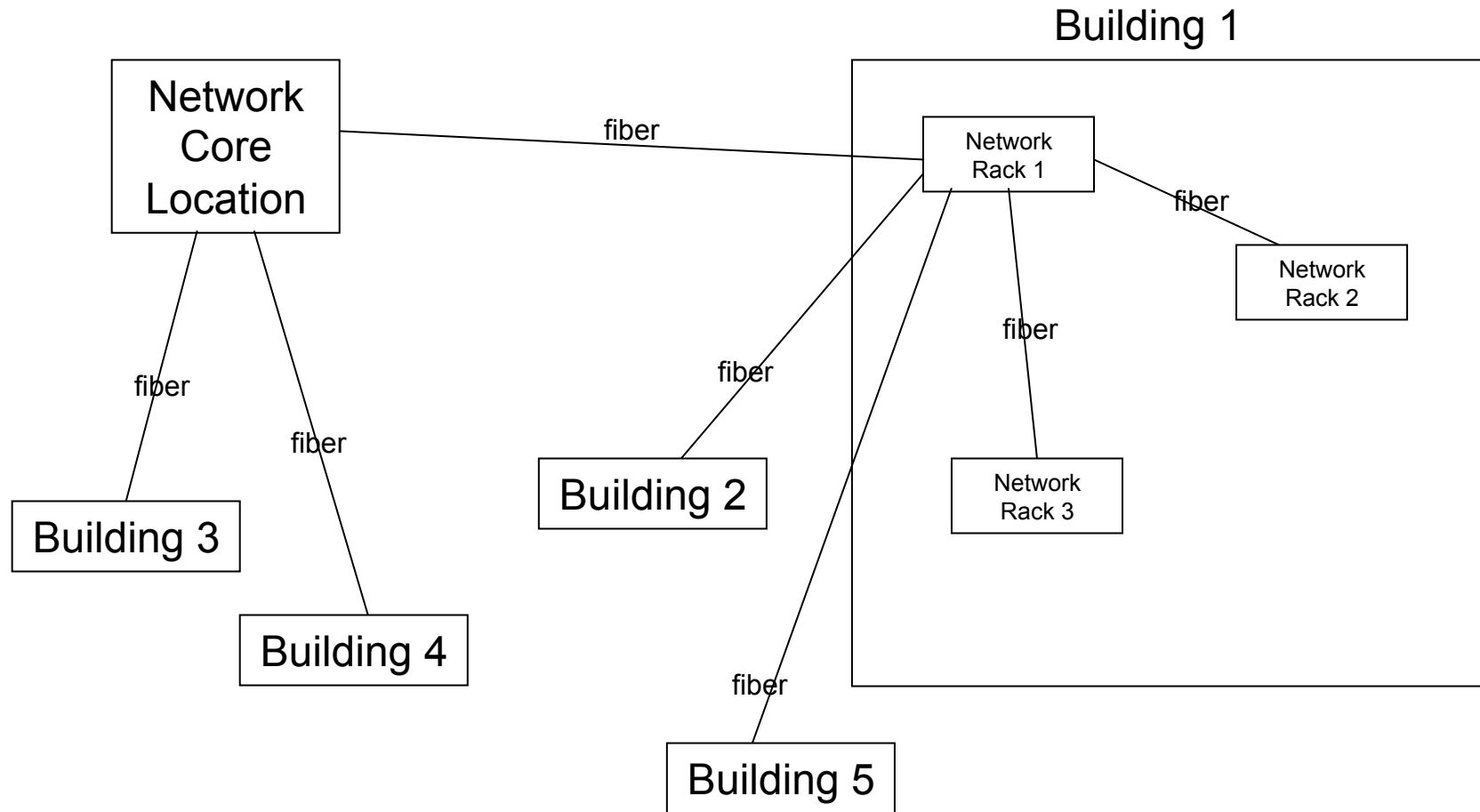

Putting it all Together

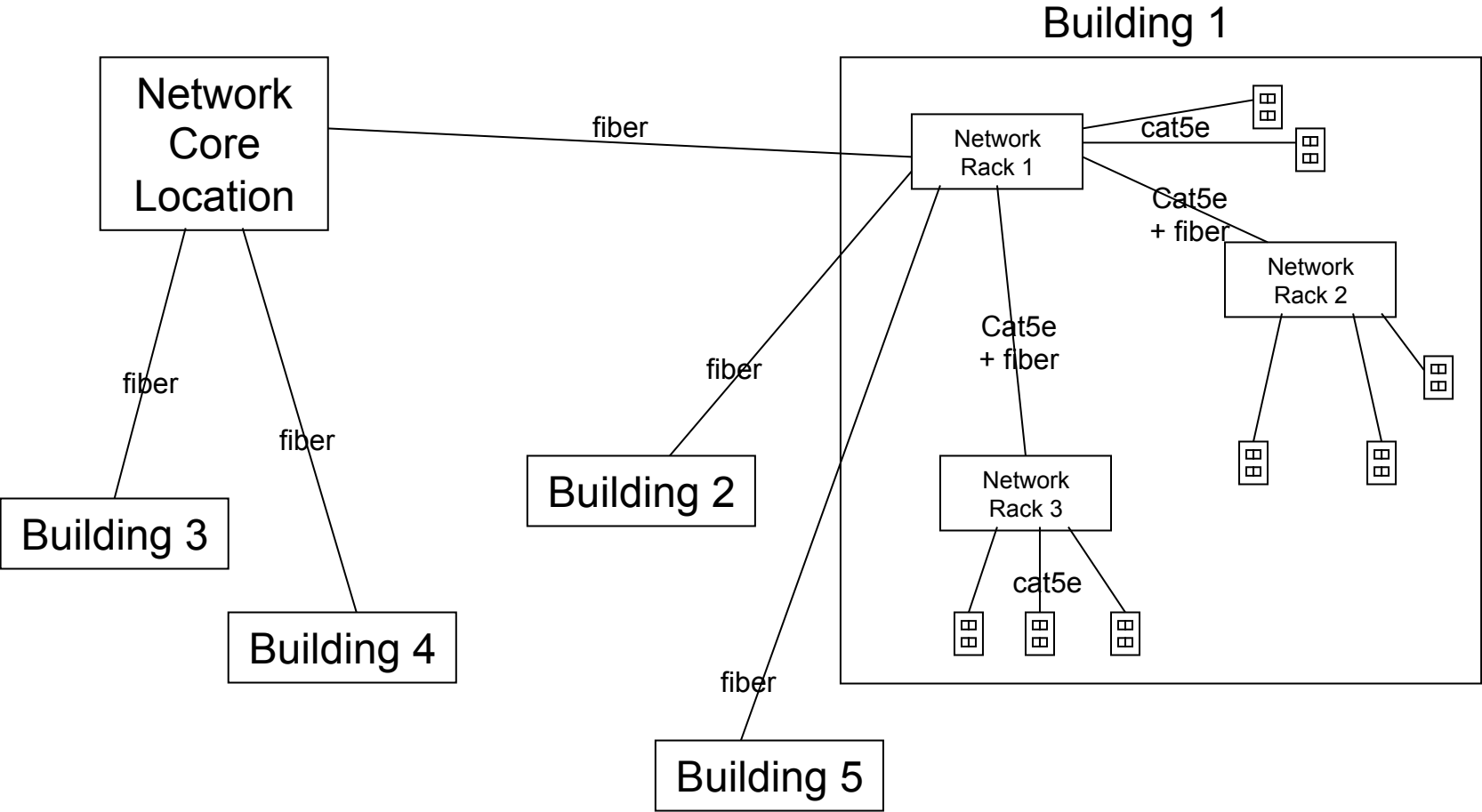

Questions?

This document is a result of work by the Network Startup Resource Center (NSRC at <http://www.nsrc.org>). This document may be freely copied, modified, and otherwise re-used on the condition that any re-use acknowledge the NSRC as the original source.



UNIVERSITY OF OREGON

